

1. Go through the HFSS tutorial (download from course web site).

Modify the structure: rotate the lower trace by 180 degrees with everything else remaining the same as in the HFSS tutorial; after the rotation, the structure should appear as shown in Figure 1 (side-view) and Figure 2 (3D-view); make sure the lumped port associated with the lower trace is also rotated with the trace; **hand in your plots for S_{11} and S_{21} versus frequency.**

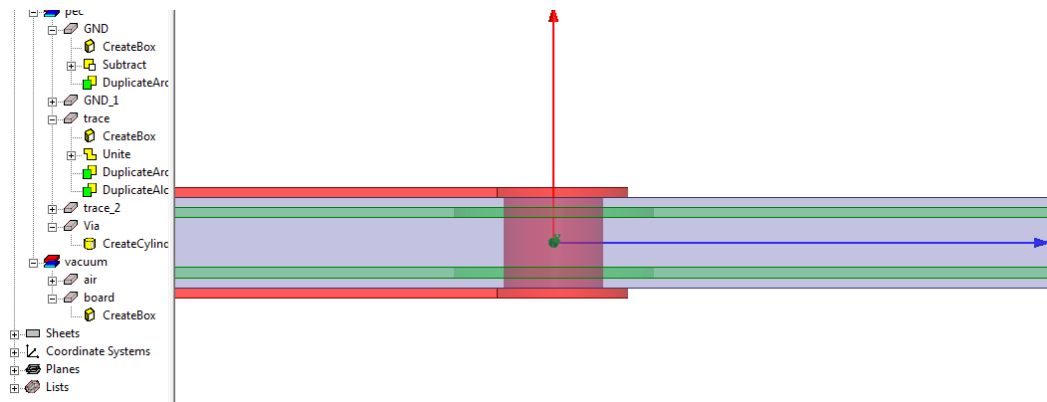

Figure 1. Side view: trace and via

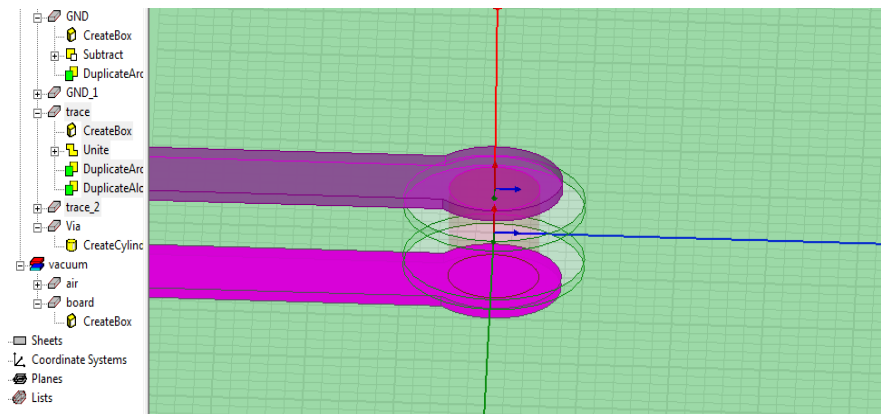

Figure 2. 3D view: trace and via

Modify the material property for the board: on the **modified design** (with the rotation), assign **FR4_epoxy** to the board in replace of the vacuum as shown in Figure 3; to view the material properties of FR4_epoxy, you can select **View/Edit Material** and the material properties are highlighted in the **red** box as shown in Figure 4; you can also assign frequency-dependent material properties as that in the **green** box in Figure 4; you are not required to use the frequency-dependent material properties in this homework.; **hand in your plots for S_{11} and S_{21} versus frequency.**

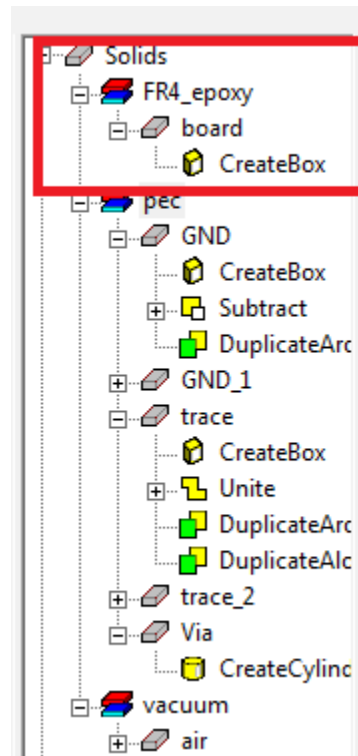

Figure 3. Assign FR4_epoxy to board

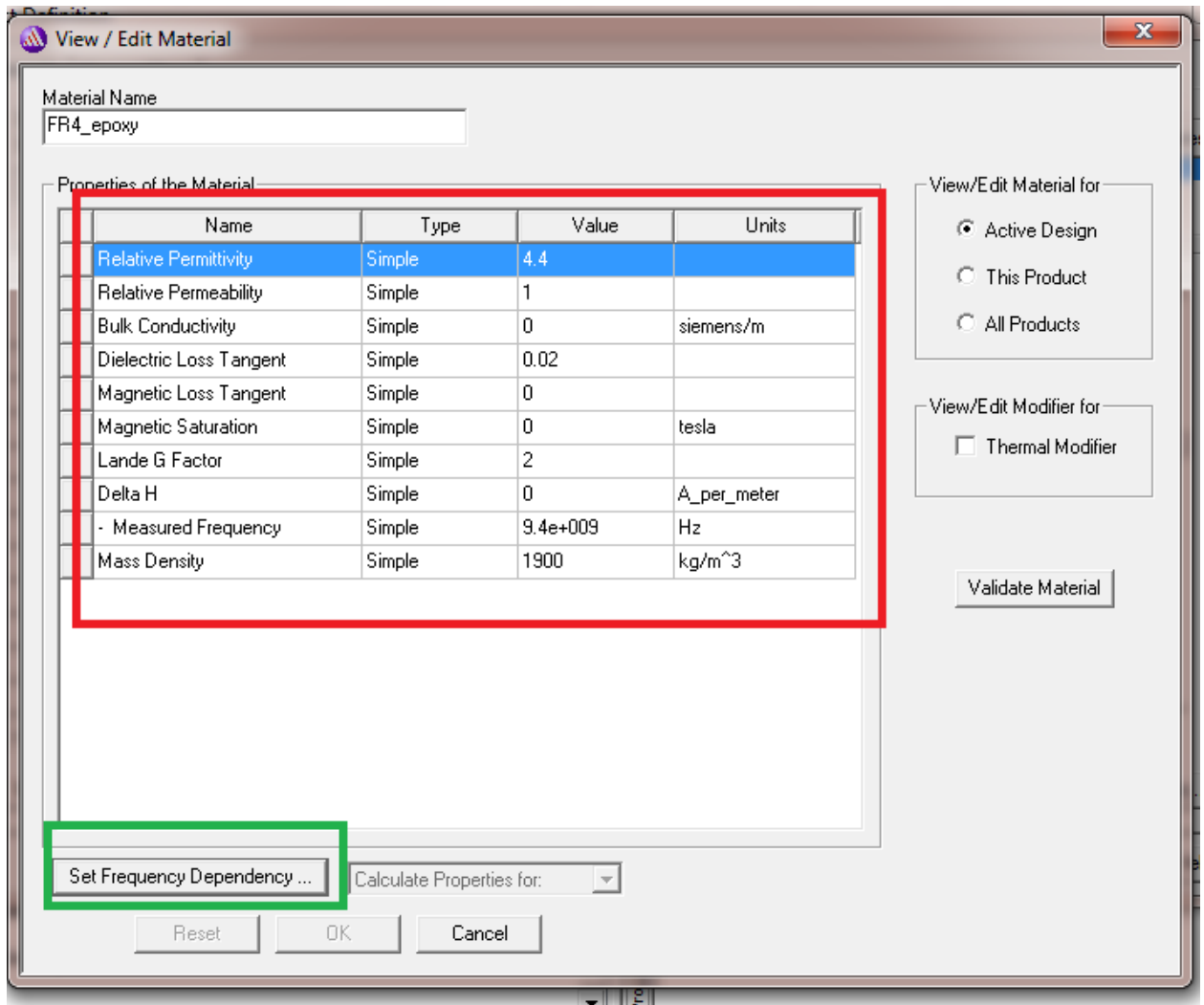

Figure 4. Material properties of FR4_epoxy