

Problem 1. Through this problem, you will learn how to perform the intersymbol interference analysis using eye diagrams. You will use the scattering parameters of the differential via pair from homework 7.

To generate the eye diagrams, you will need to send bit sequences to the system. There are two approaches for doing so in ADS (Advanced Design System):

- (a) Generate nonrepeated bit pattern using **VtBitSeq**: Sources-Time Domain-> VtBitSeq
- (b) Statistical channel analysis: Simulation-**ChannelSim**

As the error rates are very low in the modern systems, very long bit sequences have to be generated in order to accurately characterize the system. Therefore, we will use the statistical channel analysis in this homework.

Here are the key steps to accomplish the eye diagram analysis:

- (a) Save your scattering parameters in touchstone format (.sNp).
- (b) Create data items in ADS to load the scattering parameters. We use the .s2p file from homework 4 to demonstrate the idea.
- (c) Run the simulation and Plot the Density

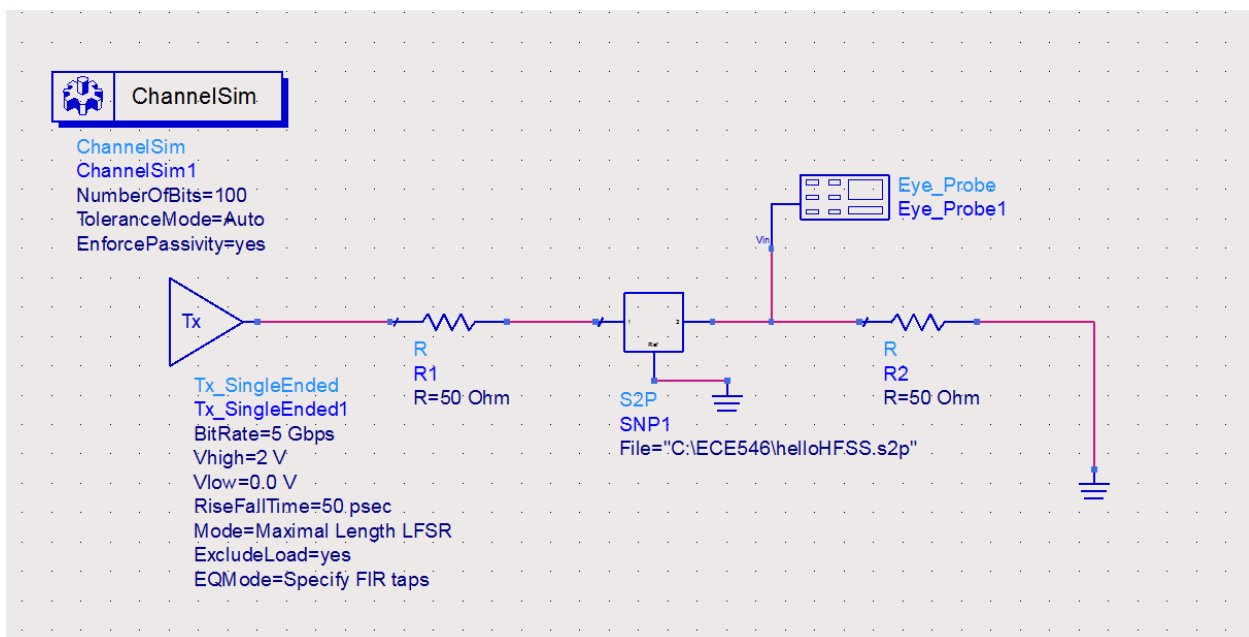

Fig 1. Schematic of Statistical Channel Analysis

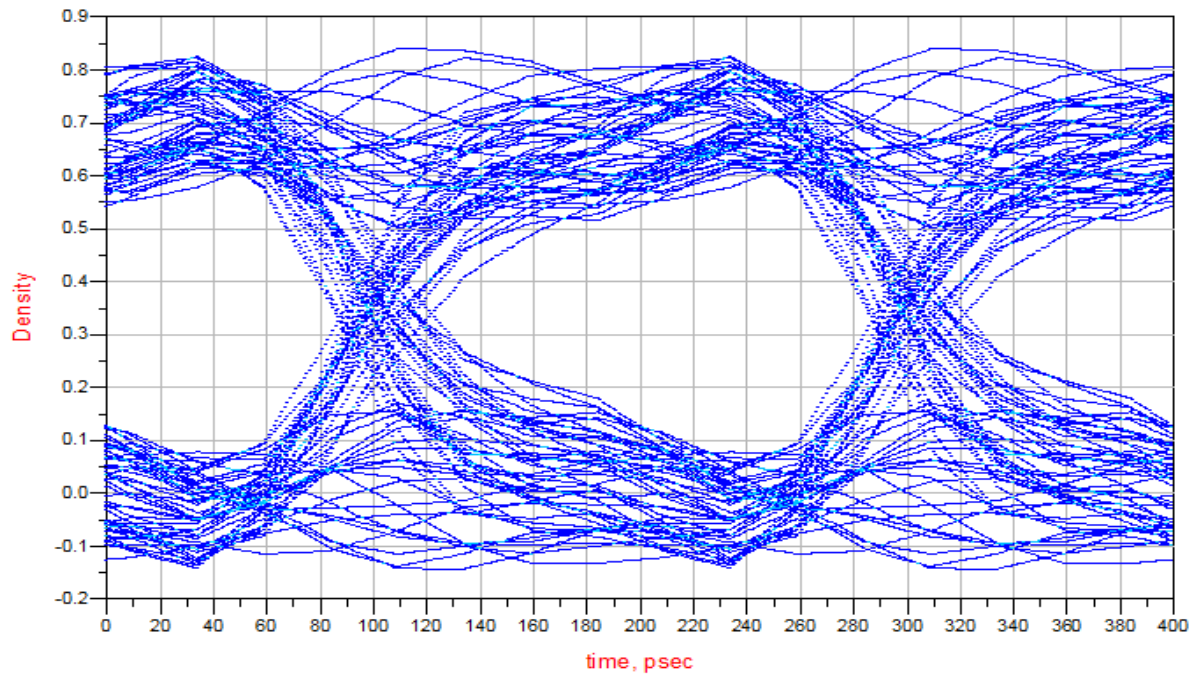

Fig 2. Eye diagram with .s2p file from Homework 4

Questions:

- (a) Use the .s4p file from howework 7 to generate the eye diagram. Teminate the two dangling ports with 50 Ohms in your four-port data item.
- (b) Try different a bit rate and rise/fall time.
- (c) Use broadband spice in ADS to generate a circuit model. Replace the data item with the circuit model and generate the eyediagram. Repeat step 2.